

# SAVIO Automated Water Level Sensor™

## Operating Manual & Specifications

Congratulations on your purchase of the SAVIO Automated Water Level Sensor.™ This device helps maintain a constant water level in ponds, pools, aquariums, spas, reservoirs, storage tanks, water cooling towers. The SAVIO Automated Water Level Sensor™ is computer-controlled. It detects low water conditions and

automatically replaces water until the pre-set level is reached. It replaces older mechanical floats, is easy to install and has no moving parts. The SAVIO Automated Water Level Sensor™ saves hours of maintenance and is the tool of choice for professionals.



## Important Safety Instructions

### WARNING - ELECTRICAL SHOCK HAZARD



This device contains electrical components that can pose significant risk of electrical shock. To guard against injury, basic safety precautions should be observed. Please read the following instructions prior to installation & operation:

### Precautions

- ✓ Do not permit children to use this product.
- ✓ Sensor wires must be continuous and not spliced.
- ✓ Solder all low voltage wire connections when possible and always use grease-filled wire nuts on low voltage connections.
- ✓ Read and follow all instructions. Save this manual for future reference.

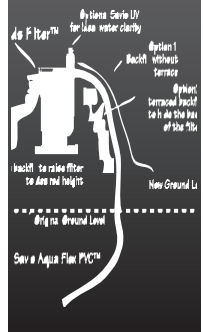
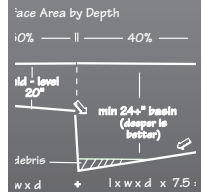
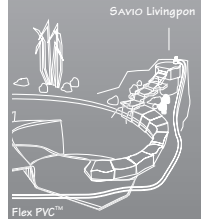
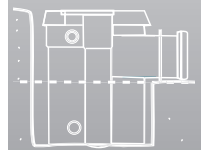

# Pre-installation

---

Choose a dry, protected location for the control box. Locate near pump equipment for easy access to power and water supply lines. The SAVIO Automated Water Level Sensor™ is designed to wire directly to a 110 VAC power source for continuous operation. It can be used in conjunction with a time clock to prevent the water supply from operating during unwanted hours.

The SAVIO Automated Water Level Sensor™ incorporates a time delay feature. This prevents the sensor from turning on unnecessarily due to wave action. The delay is seventeen seconds.

## Components

---

Control Box



Remote Sensor Housing Assembly



1" Coupling



Grease-filled Wire Nuts (2)



Half Moon Sensor



24 VAC Solenoid Valve



50' 18 Gauge Sensor Wire

Slip Fit Sensor

# Wiring Diagram

- 1) Connect black wire and white wire to 110v (see the label on the side of the control box).
- 2) Connect the green wire to ground.
- 3) Connect the 24 VAC Solenoid Valve to the blue wires using the grease-filled wire nuts provided.
- 4) Connect the two orange wires to the 50 ft Sensor Wire.

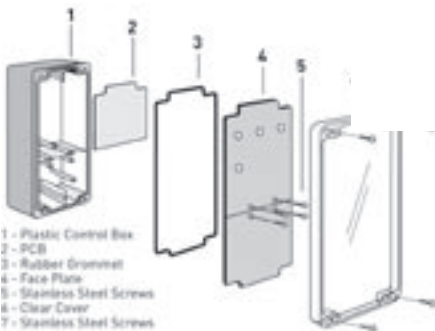
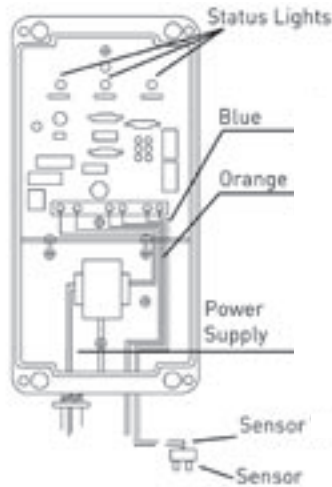
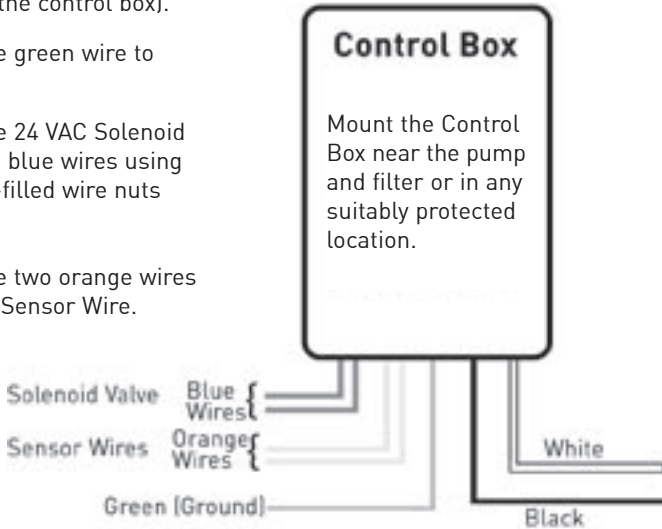

Exploded View of Control Box

# Installation

## Valve Installation:

Flush supply lines with clean water completely before installing valve.

Install the valve with the arrow pointing downstream in the direction of water flow. If installed correctly the Solenoid should be located on the downstream side of the valve.

Wrap male adapters from supply lines with 2 wraps of teflon tape. Thread adapters into both ends of the valve one turn past hand-tight.

**CAUTION: Over-tightening threaded connectors may cause damage to the valve.**

## Sensor Installation:

This kit includes two types of sensors:

(1) - Half Moon shaped sensor for mounting to a side wall or inside a skimmer. Attaches with epoxy or silicone – (not included).

(1) - 1" Slip Fit Sensor for mounting in a stand pipe or static pipe.

Both sensors ship from the manufacturer fitted to the same length of 50 ft 18 Gauge Wire. Once you have determined a mounting method for your sensor, cut the unused sensor off. Attach the free end of wire to the control unit.

## Sensor Diagram

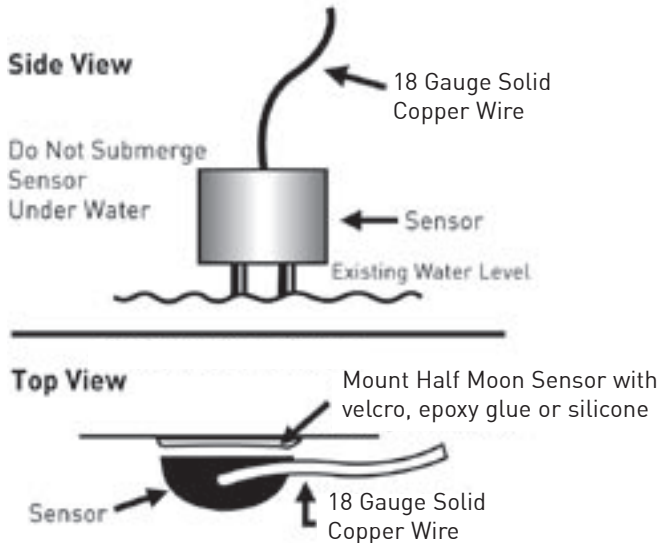

# Installation For Existing Systems

- 1) The Half Moon style sensor supplied with this kit provides the most flexibility in choosing a mounting location. Due to its small size and flat backing the sensor can easily be mounted inside a skimmer throat or other flat surface. Simply position the metal probes of the sensor so that they touch the water at the desired level. Attach sensor using velcro, epoxy glue, or silicone. NOTE: The sensor is not designed for long term submersion in water. Place only metal probes in water.
- 2) Turn the water off before installing valve. Install the 24 VAC Solenoid Valve into a supply line coming from the house or irrigation system. Place the supply line either before or after the filter. Installing an inexpensive anti-siphon valve at this time ensures against accidental draining of the pond. Position the water supply output so water enters the pond with as little splash as possible to minimize waves.
- 3) Install the Control Box in a dry, protected location. Follow the wiring instructions provided on page 3 to ensure safe operation.
- 4) After installation is complete, turn on the water supply. Switch the power on to the Control Box unit. The system is now operational.

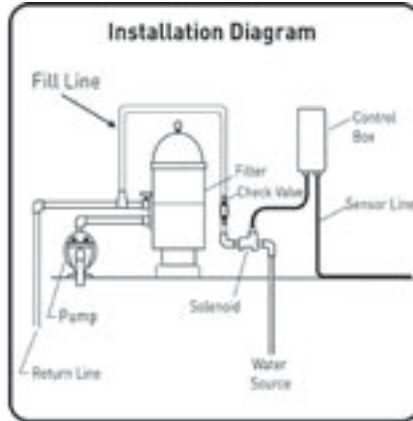

## Installation Diagram

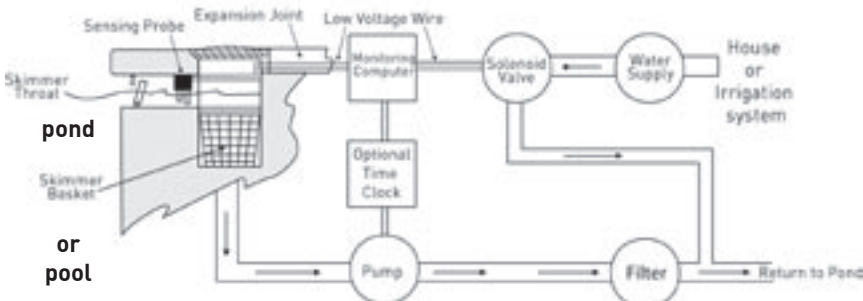

# New Construction Installation

- 1) The Slip Fit Sensor supplied with this kit is designed to be fitted using a coupling to 1" PVC. The accompanying illustrations show how to install a stilling line and static pipe. Simply position the metal probes of the sensor so they touch the water at the desired water level. **NOTE:** The sensor is not designed for long term submersion in water. Place only the metal probes in water.  
Install the supply line either before or after the filter. Installing an inexpensive anti-siphon valve at this time will ensure against accidental draining of the pond. Position the water supply output close to the water with as little splash as possible to minimize waves.
- 2) Turn the water off before installing valve. Install the 24 VAC Solenoid Valve into a supply line coming from the house or irrigation system. Install the Control Box in a dry, protected location. Locate near pump equipment for easy access to power and water supply lines. Follow the wiring instructions provided to ensure safe operation.
- 3) Install the Control Box in a dry, protected location. Locate near pump equipment for easy access to power and water supply lines. Follow the wiring instructions provided to ensure safe operation.
- 4) Once the system is installed, turn on the water supply. Switch the power on to the Control Box. The system is now operational.

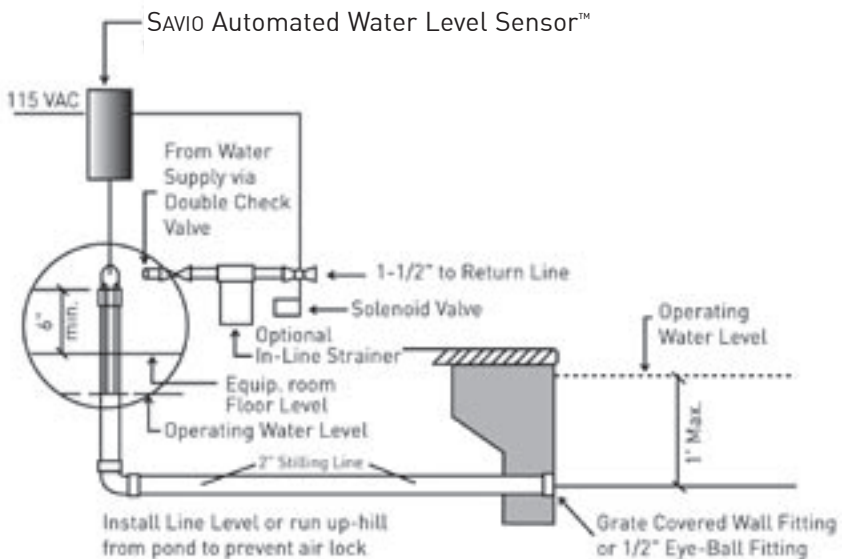

# New Construction

## Detail - Installation Method

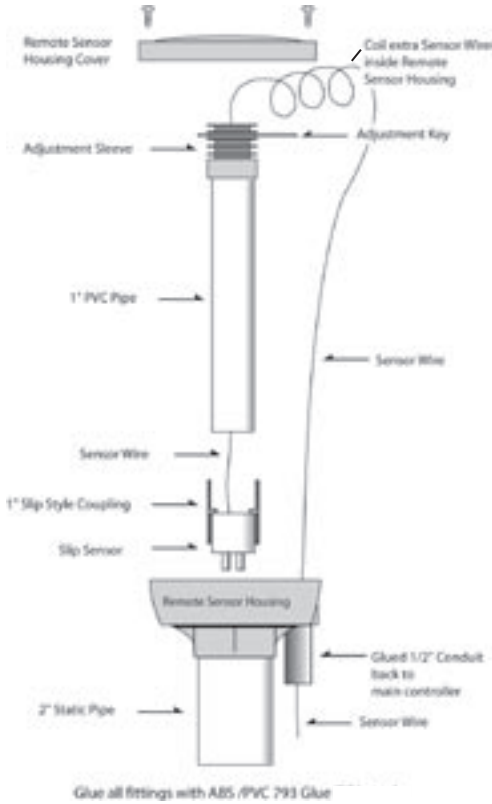

## Deck Lid Installation Method Details

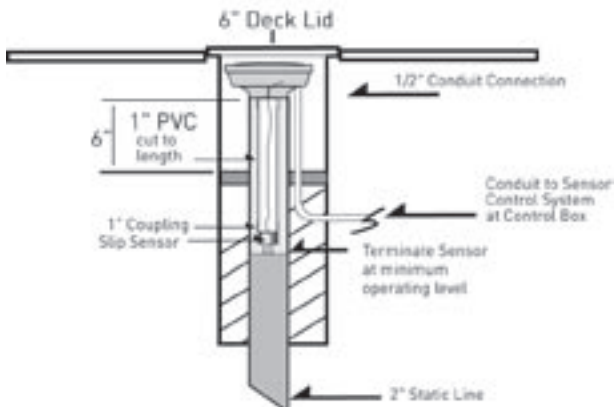

# Warranty

To receive free Water gardening Newsletters, send in the enclosed warranty card. SAVIO Engineering, Inc. provides a manufacturer's limited warranty of 12 months from the date of purchase. Within the warranty period SAVIO will repair all faulty materials or manufacturing deficiencies, or shall replace the device at their discretion, free of charge. This warranty does not cover any faults caused by improper use or installation of the device or as a result of wear and tear. SAVIO Engineering, Inc. does not assume liability for consequential damage caused by the failure of the Water Level Sensor. Warranty is void if used as part of a rental program or not in accordance with these instructions. For warranty claims, please contact customer service. Transport the device in the original packaging to avoid damage during transport. SAVIO is not responsible for damage resulting from shipping.

## Customer Service Information



**SAVIO Engineering, Inc.**

**<http://www.savio.cc>**

**Email: [support@savio.cc](mailto:support@savio.cc)**

**8 Water Garden Way**

**Santa Fe, NM 87508 USA**

## SAVIO manufactures a full line of water gardening products for healthy, clean living ponds:

SAVIO Skimmerfilters™

SAVIO Stainless Steel Submersible Pumps™

SAVIO Springflo Bio Filter Media™

SAVIO Mud Sweeper Vacuum™

SAVIO Automated Water Level Sensor™

SAVIO Livingponds Filters™

SAVIO Waterfall Filters™

SAVIO Aqua Flex PVC™

SAVIO Natural Barley Extract™

SAVIO Natural Beneficial Bacteria™

