

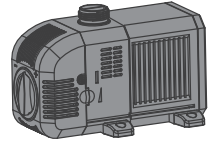

Model Number

90082

90083



# INSTALLATION & OPERATION MANUAL

## SUBMERSIBLE POND PUMP

### SAFETY GUIDELINES

Carefully read, understand and follow all safety instructions in this manual.

**⚠** This is the safety alert symbol. When you see this symbol, look for one of the following signal words.

**⚠ DANGER** Indicates a hazardous situation which, if not avoided, will result in death or serious injury.

**⚠ WARNING** Indicates a hazardous situation which, if not avoided, could result in death or serious injury.

**⚠ CAUTION** Indicates a hazardous situation which, if not avoided, could result in minor or moderate injury.

**NOTICE** Indicates important information, that if not followed, may result in damage to the equipment.

### SAFETY INFORMATION

Read these warnings carefully. Know the application and limitations of this pump. Failure to follow these warnings could result in serious bodily injury and/or property damage.

**⚠ DANGER** RISK OF ELECTRICAL SHOCK. Disconnect and lockout power supply before removing existing pump or installing or servicing this pump.

**⚠ DANGER** RISK OF ELECTRICAL SHOCK. This pump is supplied with a grounding conductor and grounding type attachment plug. To reduce the risk of electric shock, be certain that it is connected only to a properly grounded, grounding type receptacle. For added safety, it is highly recommended to connect this pump to a GFCI (Ground Fault Circuit Interrupter) outlet. Connect only to a receptacle that is adequately rated for the voltage and amperage of this pump.

**⚠ WARNING** The installation of this pump must be in accordance with the National Electric Code (NEC), Uniform Plumbing Code (UPC), International Plumbing Code (IPC) as well as all applicable local codes and ordinances.

**⚠ CAUTION** Do not install this pump in any location classified as hazardous by the National Electrical Code, ANSI/NFPA70.

**⚠ DANGER** Do not use this pump to pump flammable or explosive fluids such as gasoline, kerosene, etc. Do not use this pump in flammable or explosive environments. Use only with liquids compatible with pump component materials.

**⚠ WARNING** RISK OF ELECTRICAL SHOCK. This pump has not been investigated for use in swimming pool or marine areas.

**⚠ WARNING** RISK OF ELECTRICAL SHOCK. DO NOT use the power cord to remove or lower the pump into the water source. The cord may pull apart exposing bare wires which could cause a fire or electrical shock. Grasp pump body for installing and removing the pump from water source.

**⚠ WARNING** Do not run the pump dry. This pump relies on water for cooling. Running the pump dry can cause the pump to overheat and the possibility of burns to anyone that handles the pump. Running the pump dry will void the warranty.

## SAFETY INFORMATION (CONTINUED)

- ⚠ WARNING** Do not expose pump to freezing temperatures. Discharge pipe or hose (not included) should not be exposed to freezing temperatures as this may cause damage to the pump.
- ⚠ WARNING** Do not use this pump for potable/drinking water. Use only in applications for which the pump is designed for.
- ⚠ WARNING** According to the state of California (Prop 65), this product contains chemicals known to the state of California to cause cancer and birth defects or other reproductive harm.
- ⚠ WARNING** DO NOT UNDER ANY CIRCUMSTANCES REMOVE THE GROUND PIN.  
The 3-prong plug must be inserted into a mating 3-prong grounded receptacle. If the installation does not have such a receptacle, it must be changed to the proper type, wired and grounded in accordance with the National Electrical Code and all applicable local codes and ordinances.
- ⚠ WARNING** All wiring must be performed by a qualified electrician.
- ⚠ WARNING** Keep hands clear of suction and discharge openings. To prevent injury, never insert fingers into pump while it is plugged in.
- ⚠ WARNING** Do not handle this pump with wet hands or while standing on wet or damp surfaces or in water.
- ⚠ CAUTION** If a flexible discharge hose is used, make sure the pump is secured to prevent movement. Failure to secure the pump could result in pump malfunction.
- ⚠ CAUTION** This pump motor is equipped with an automatic resetting thermal protector and may restart unexpectedly.
- ⚠ DANGER** When a pump is in its application, do not touch the motor, pipes, or water until the unit is unplugged or electrically disconnected.
- ⚠ WARNING** The pump should only be used with liquids compatible with pump component materials. If the pump is used with liquids incompatible with the pump components, the liquid can cause failure to the electrical insulation system resulting in electrical shock.
- ⚠ CAUTION** This equipment must not be handled or used by children. Children should not play with the unit or within the immediate vicinity.
- ⚠ CAUTION** The pump has been evaluated for use with fresh water only.
- NOTICE** Pumping sand or other abrasives can damage the pump and will void the warranty.
- NOTICE** Do not pump heated liquids. Pump operating range is from 34°F to 120°F
- NOTICE** Do not use in salt water or highly chlorinated water.
- NOTICE** Failure to carry out routine maintenance or leaving the pump under reduced or no-flow conditions for long periods (i.e, blocked pump filter) may result in accelerated wear.
- ⚠ CAUTION** Your pump motor is thermally protected. It is not recommended for pumping liquids over 120° F (49° C). The thermal overload protector will automatically shut down the pump in an overheat situation. The pump will reset itself once the pump cools down. This overload is designed as a safety device and it will fail after repeated use. Normal operation is for fluids between 34° F & 120° F.
- ⚠ CAUTION** All repairs must be made by an authorized service center.
- ⚠ CAUTION** The pump motor is hermetically sealed in the housing and does not require any service. Disassembly of the motor housing or modification of the power cord will void the warranty.

## DESCRIPTION

This Submersible Pond Pump is designed to circulate water throughout ponds and water features.

## SPECIFICATIONS

Model	90082	90083
Max Gallons Per Hour	1200	1800
Volts	120	120
Amps	1.6	2.1
Hz	60	60
Watts	80	150
Max Height	12-1/2 ft.	16-1/2 ft.
Discharge Size	1 in.	1 in.
Liquid Temp. Range	34°F to 120°F	34°F to 120°F
Cord Length	16 ft.	16 ft.
Pump Housing Construction	Thermoplastic	Thermoplastic
Drive Type	Magnetic	Magnetic
Adjustable Flow Control	Yes	Yes
Removable Filter	Yes	Yes
Adapters Included	<ul style="list-style-type: none"> <li>· 1 in. FPT x 1 in. MPT or 3/4 in. FPT Adapter</li> <li>· 1 in. FPT x 1/2 in. BARB</li> <li>· 1 in. FPT x 1-1/4 in. or 1 in. or 3/4 in. BARB</li> </ul>	<ul style="list-style-type: none"> <li>· 1 in. FPT x 1 in. MPT or 3/4 in. FPT Adapter</li> <li>· 1 in. FPT x 1/2 in. BARB</li> <li>· 1 in. FPT x 1-1/4 in. or 1 in. or 3/4 in. BARB</li> </ul>

## PERFORMANCE

Model	0 ft.	3 ft.	7 ft.	10 ft.	13 ft.	16 ft.	Max Lift
90082	1200	1050	660	340	26	-	12-1/2 ft
90083	1800	155	1190	870	528	30	16-1/2 ft

Gallons per hour at discharge height.

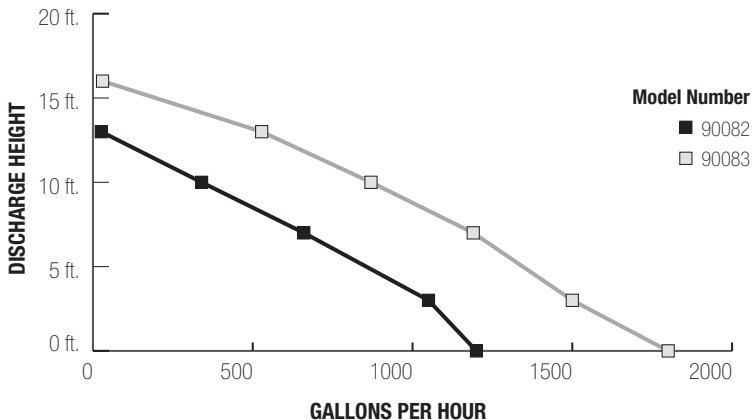

Height and/or piping restriction will reduce the pump output performance. It is recommended to use the same size or larger pipe as the pump discharge for optimum performance.

## **⚠️WARNING**

**RISK OF ELECTRICAL SHOCK:** Disconnect and lockout power supply before installation, operation or adjusting discharge flow.

## **⚠️WARNING**

Review safety instructions before installation, operation or adjusting discharge flow.

### **INSTALLATION**

1. Choose the correct adapter for the application.
2. Thread adapter into pump discharge.
3. Attach pipe or tubing to the adapter.
4. Run pipe or tubing to pond feature (not included) or auxiliary pond filter (not included).

**NOTE:** For maximum flow it is recommended to use the largest fittings and pipe (not included).

5. Fully submerge pump in water source.
6. Place pump on a solid surface where pump is secure and does not move.
7. The pump will operate in any direction as long as the entire pump is fully submerged in the water source.

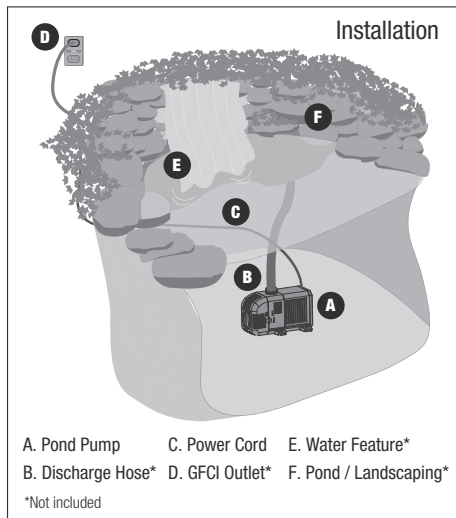

### **OPERATION**

1. Plug the pump power cord (C) into a 120 volt grounded outlet. The use of a GFCI outlet (not included) is highly recommended.
2. Pump will self prime and move water.

**NOTE:** If pump does not move water, ensure that the pump is fully submerged in water. Unplug pump and plug in pump to re-prime. Repeat as necessary.

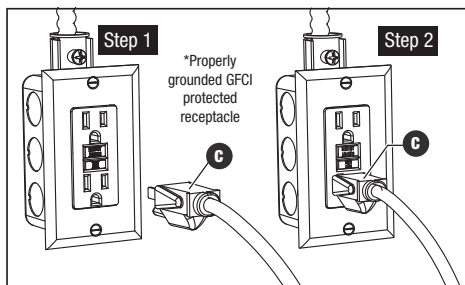

### **ADJUST DISCHARGE FLOW**

1. Unplug pump power cord from power source.
2. Adjust the flow rate by adjusting the flow control valve located on the front of the pump.
3. To increase flow turn the flow control clockwise towards the plus (+).
4. To decrease flow turn the flow control counter clockwise towards the negative (-).

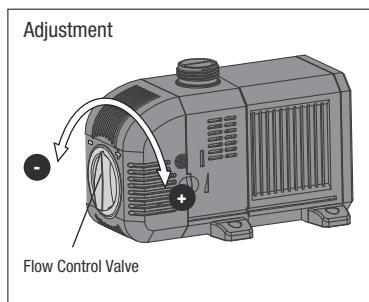



**RISK OF ELECTRICAL SHOCK:** Disconnect and lockout power supply before removing or servicing pump.



Review safety instructions before removing or servicing pump.

## MAINTENANCE - PUMP FILTER

1. Unplug pump power cord from power source.
2. Remove the front plate/screen (B) by gently pushing in on the two tabs (B-1 & B-2) located on the sides of the plate/screen (B) and gently separating it from the volute plate (D).
3. Remove filter (C) and thoroughly clean using fresh water.
4. Reassemble the parts in reverse order.

## MAINTENANCE - MAGNETIC DRIVE

1. Unplug pump power cord from power source.
2. Remove the adjustment valve (A) by gently separating it from the front/plate screen (B). Note: Valve (A) must point straight up position (A-1) to remove from plate / screen (B).
3. Remove the front plate/screen (B) by gently pushing in on the two tabs (B-1 & B-2) located on the sides and gently separate it from the volute plate (D).
4. Remove filter (C).
5. Turn the volute plate (D) counter-clockwise and remove it from the pump body (G).
6. Remove the shaft/impeller assembly (E) from impeller cavity.
7. Clean any corrosion or debris from the filter cover, volute, impeller, shaft, and the impeller cavity using fresh water.
8. Reassemble the parts in reverse order.
9. Inspect the power cord to ensure that it is in good condition and has no nicks or cuts.

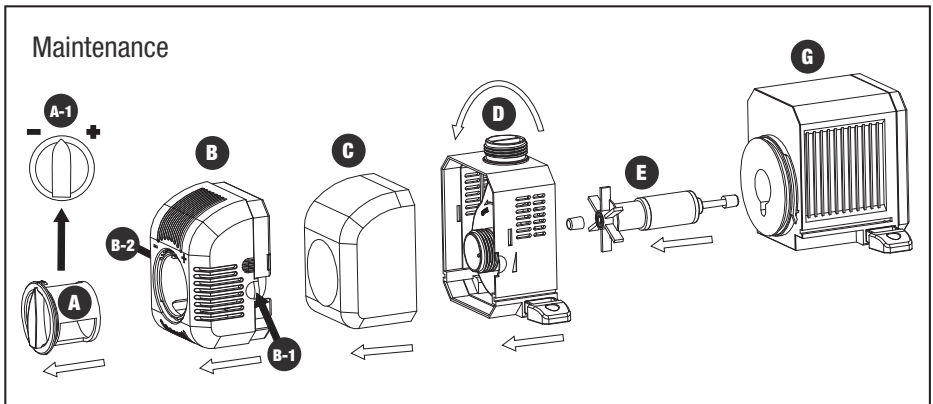

## MAINTENANCE - WINTER CARE

1. Unplug pump power cord from power source.
2. Remove pump from water source.
3. Disconnect any pipe or hose connected to the pump.
4. Thoroughly clean the pump and filter.
5. Store the pump in frost free area with a temperature of 34°F or above

# REPLACEMENT PARTS

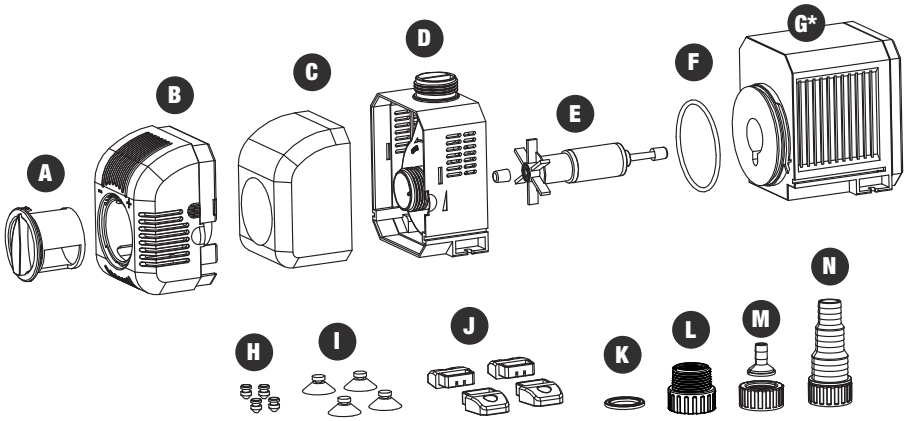

Description	90082	90083
A Adjustment Valve		
B Front Plate / Screen	99878	99878
C Filter		
D Volute Plate	99879	99879
E Shaft/Impeller Assembly	99884	99884
*G Pump Body / Motor	*	*
H Rubber Feet		
I Suction Cups	99882	99882
J Pump Support Feet		
K Discharge O-Ring		
L 1 in. FPT x 1 in. MPT or 3/4 in. FPT Adapter	99881	99881
M 1 in. FPT x 1/2 in. BARB		
N 1 in. FPT x 1-1/4 in. or 1 in. or 3/4 in. BARB		

\*If motor fails, replace entire pump.

**TO ORDER PARTS PLEASE CALL: 800.495.9278**

# TROUBLESHOOTING

Problem	Possible Causes	How to Correct	
If the pump does not start or run.	Pump is not plugged in; switch or breaker is turned off.	Plug pump in or turn on switch/breaker.	
	Check for blown fuses or tripped circuit breakers or tripped GFCI outlets.	Replace fuse, reset breaker, reset GFCI outlet.	
	Motor thermal protector tripped.	Allow pump to cool, pump will reset automatically.	
If the pump runs but moves little or no water.	Clogged discharge hose/pipe.	Remove clog.	
	Low line voltage.	Check wire size and increase if necessary.	
	Clogged intake screen.	Clean or replace screen.	
	Clogged filter.	Clean filter.	
	Kinked or twisted discharge hose.	Remove kink or twist.	
	Worn, damaged or clogged pump parts.	Inspect for wear, damage or clog and clean or replace part if necessary.	
	The pump is not priming.	Ensure that the inlet of the pump is below the water surface.	
	The pump is not priming.	Unplug pump from power source cord, wait a few minutes and plug pump back into power source.	
	The flow control valve is mis-adjusted.	Turn the flow control valve until the desired flow is reached.	
	Low water level.	Raise water level until pump is fully submerged.	
Pump runs intermittently.	The pump is overheating and is tripping the motor thermal overload protection.	Air-lock in the impeller chamber.	Unplug pump and plug in pump to eliminate air-lock. Repeat procedure if necessary.
			Check to see that there is no debris clogging the suction port.
			Submerge pump to a greater depth.
			Raise water level.
			Move pump to a shaded area in the water source to reduce exposure to the sun.

## LIMITED WARRANTY – SUBMERSIBLE POND PUMPS

Manufacturer warrants the products specified in this warranty to be free from defects in material or workmanship for one (1) year from date of purchase. During the time period and subject to the terms and conditions, the manufacturer will repair or replace to the original user or consumer any portion of this product which proves to be defective due to materials or workmanship. At all times the manufacturer shall have and possess the sole right and option to determine whether to repair or replace defective equipment, parts, or components. The manufacturer has the option to inspect any product returned under warranty to confirm that the warranty applies before repair or replacement under warranty is approved. This warranty sets forth the manufacturer's sole obligation and purchaser's exclusive remedy for defective product. Return defective product to the place of purchase for warranty consideration.

### WARRANTY PERIOD - PRODUCTS:

If, within the duration of product use by the original user, this product proves to be defective due to materials or workmanship, the product shall be repaired or replaced at the manufacturer's option, subject to the terms and conditions set forth in this warranty statement. Proof of purchase is required for warranty consideration. In the absence of suitable proof of the purchase date, the effective period of this warranty is 12 months from the product's date of manufacture.

### LABOR, ETC. COSTS:

The manufacturer shall IN NO EVENT be responsible or liable for the cost of field labor or other charges incurred by any customer in removing and/or affixing any product, part, or component thereof.

### PRODUCT IMPROVEMENTS:

The manufacturer reserves the right to change or improve its products or any portions thereof without being obligated to provide such a change or improvement for units sold and/or shipped prior to such change or improvement.

### GENERAL TERMS AND CONDITIONS:

This warranty shall not apply to damage due to acts of God, normal wear and tear, normal maintenance services and the parts used in connection with such service, lightning or conditions beyond the control of the manufacturer, nor shall it apply to products which, in the sole judgment of the manufacturer, have been subject to negligence, abuse, accident, misapplication, tampering, alteration; nor due to improper installation, operation, maintenance or storage; nor to excess of recommended maximums as set forth in the instructions. Warranty will be VOID if any of the following conditions are found:

1. Product is used for purposes other than those for which it was designed and manufactured.
2. Product not installed in accordance with applicable codes, ordinances, and good trade practices.
3. Product connected to voltage other than indicated on nameplate or labels.
4. Pump exposed to but not limited to the following: sand, gravel, cement, grease, plaster, mud, tar, oil, gasoline, solvents or other abrasive or corrosive substances.
5. Pump has been used for pumping liquids above 120°F.
6. Pump allowed to operate dry (liquid supply cut off).

### DISCLAIMER:

Any oral statements about the product made by the seller, the manufacturer, the representatives, or any other parties do not constitute warranties, shall not be relied upon by the user, and are not part of the contract for sale. Seller's and the manufacturers only obligation, and buyer's only remedy, shall be the replacement and/or repair by the manufacturer of the product as described above. **NEITHER SELLER NOR THE MANUFACTURER SHALL BE LIABLE FOR ANY INJURY, LOSS OR DAMAGE, DIRECT, INCIDENTAL OR CONSEQUENTIAL (INCLUDING, BUT NOT LIMITED TO, INCIDENTAL OR CONSEQUENTIAL DAMAGES FOR LOST PROFITS, LOST SALES, INJURY TO PERSON OR PROPERTY, OR ANY OTHER INCIDENTAL OR CONSEQUENTIAL LOSS), ARISING OUT OF THE USE OR THE INABILITY TO USE THE PRODUCT, AND THE USER AGREES THAT NO OTHER REMEDY SHALL BE AVAILABLE TO IT.** Before using, the user shall determine the suitability of the product for his/her intended use, and user assumes all risk and liability whatsoever in connection therewith.

**THE WARRANTY AND REMEDY DESCRIBED IN THIS LIMITED WARRANTY IS AN EXCLUSIVE WARRANTY AND REMEDY AND IS IN LIEU OF ANY OTHER WARRANTY OR REMEDY, EXPRESSED OR IMPLIED, WHICH OTHER WARRANTIES AND REMEDIES ARE HEREBY EXPRESSLY EXCLUDED, INCLUDING BUT NOT LIMITED TO ANY IMPLIED WARRANTY OF MERCHANTABILITY OR FITNESS FOR A PARTICULAR PURPOSE, TO THE EXTENT EITHER APPLIES TO A PRODUCT SHALL BE LIMITED IN DURATION TO THE PERIODS OF THE EXPRESSED WARRANTIES GIVEN ABOVE.**

Some states and countries do not allow the exclusion or limitations on how long an implied warranty lasts or the exclusion or limitation of incidental or consequential damages, so the above exclusion or limitations may not apply to you. This warranty gives you specific legal rights, and you may also have other rights which vary from state to state.

**SUPERIORPUMP.COM**  
**CUSTOMER SERVICE: 800.495.9278**