

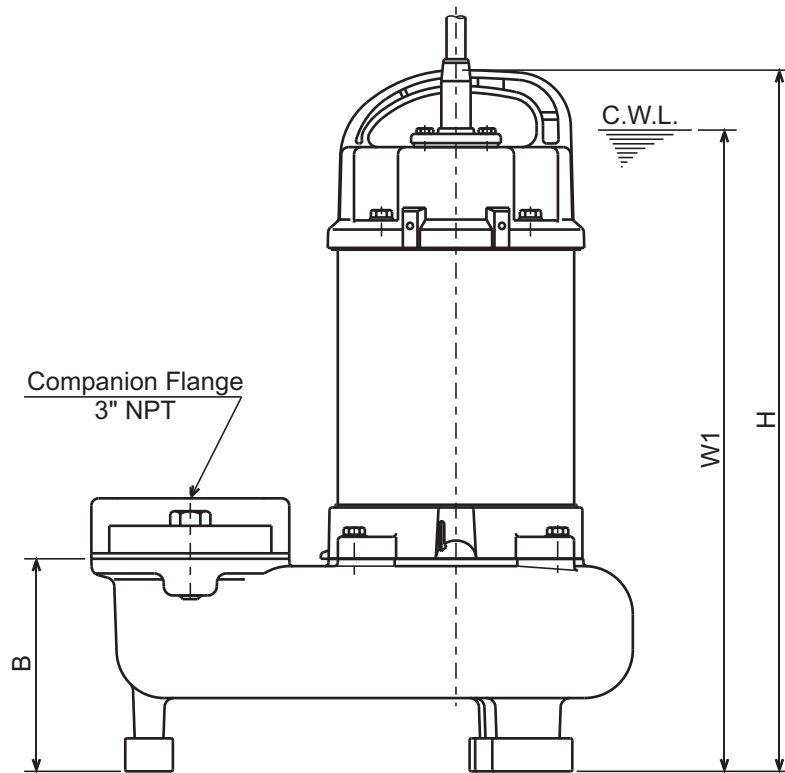

12-PN
HIGH VOLUME POND PUMP

DIMENSIONS

12-PN

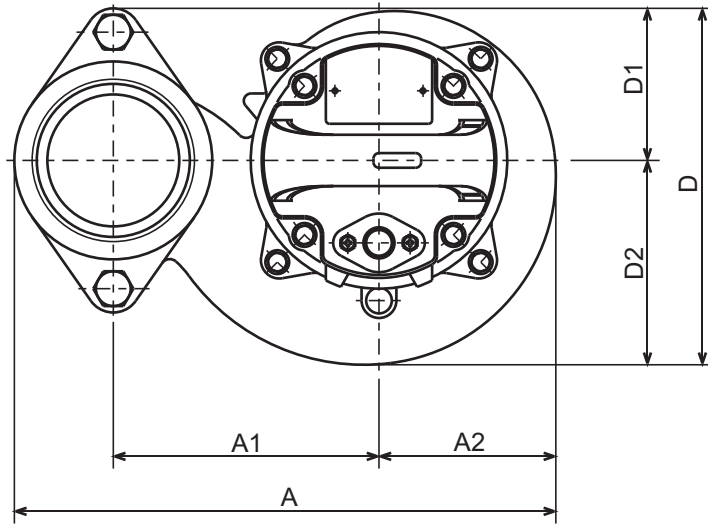

C.W.L. :Continuous running Water Level

DIMENSIONS:USCS (Inch)

Model	HP	NOM. SIZE	Pump & Motor								C.W.L.	Wt. (lbs.)
			A	A1	A2	B	D	D1	D2	H	W1	
12-PN	1	3"	11 5/8	5 11/16	3 13/16	4 9/16	7 11/16	3 1/4	4 3/8	15 1/16	13 3/4	31.9

DIMENSIONS:METRIC (mm)

Model	kW	NOM. SIZE	Pump & Motor								C.W.L.	Wt. (kg)
			A	A1	A2	B	D	D1	D2	H	W1	
12-PN	0.75	80	296	145	97	116	195	83	112	383	350	14.5