

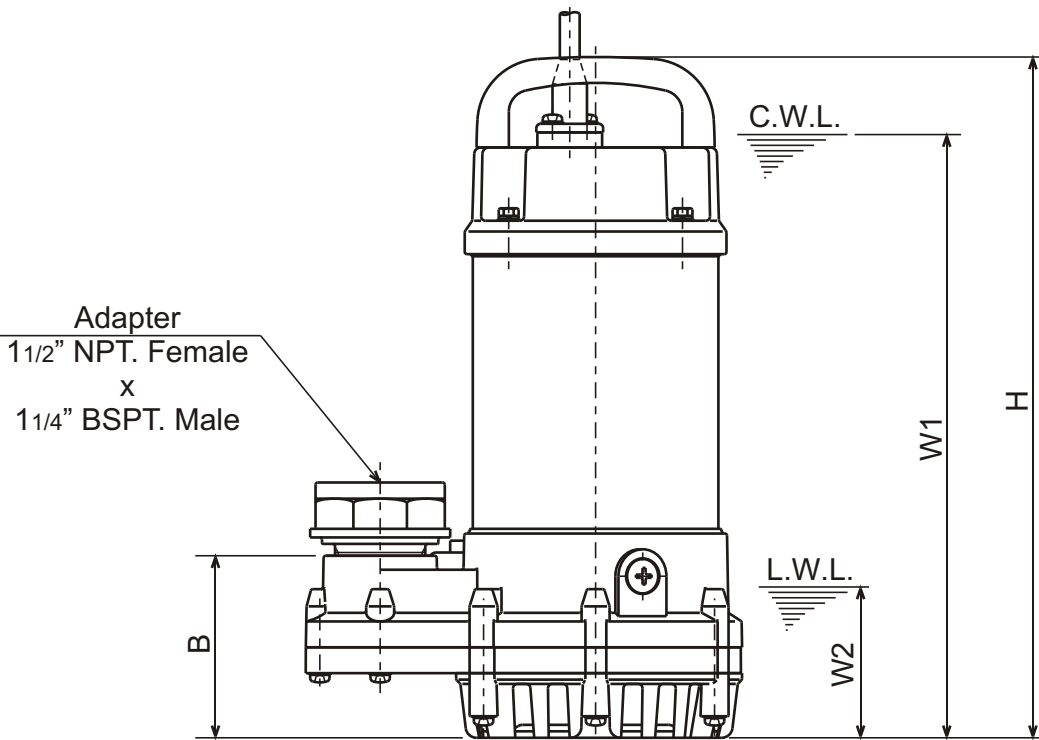

OM-SERIES
(FRP) SEMI-VORTEX - WATER FEATURE PUMP

DIMENSIONS

2OM

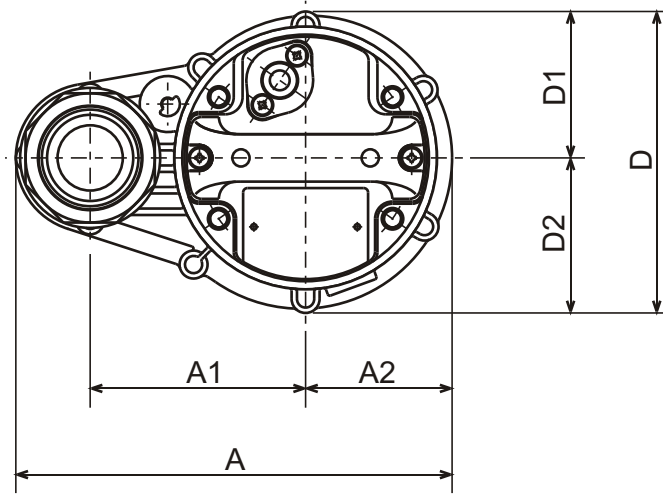

C.W.L. : Continuous running Water Level
L.W.L. : Lowest running Water Level

DIMENSIONS :USCS (Inch)

Model	HP	NOM. SIZE	Pump & Motor								C.W.L. W1	L.W.L. W2	Wt. (lbs.)
			A	A1	A2	B	D	D1	D2	H			
2OM	1/5	1 1/2"	8	3 15/16	2 11/16	3 3/8	5 1/2	2 11/16	2 13/16	12 7/16	11	2 3/4	13.0

DIMENSIONS :METRIC (m m)

Model	kW	NOM. SIZE	Pump & Motor								C.W.L. W1	L.W.L. W2	Wt. (kg)
			A	A1	A2	B	D	D1	D2	H			
2OM	0.15	40	203	100	68	85	140	68	72	316	280	70	5.9