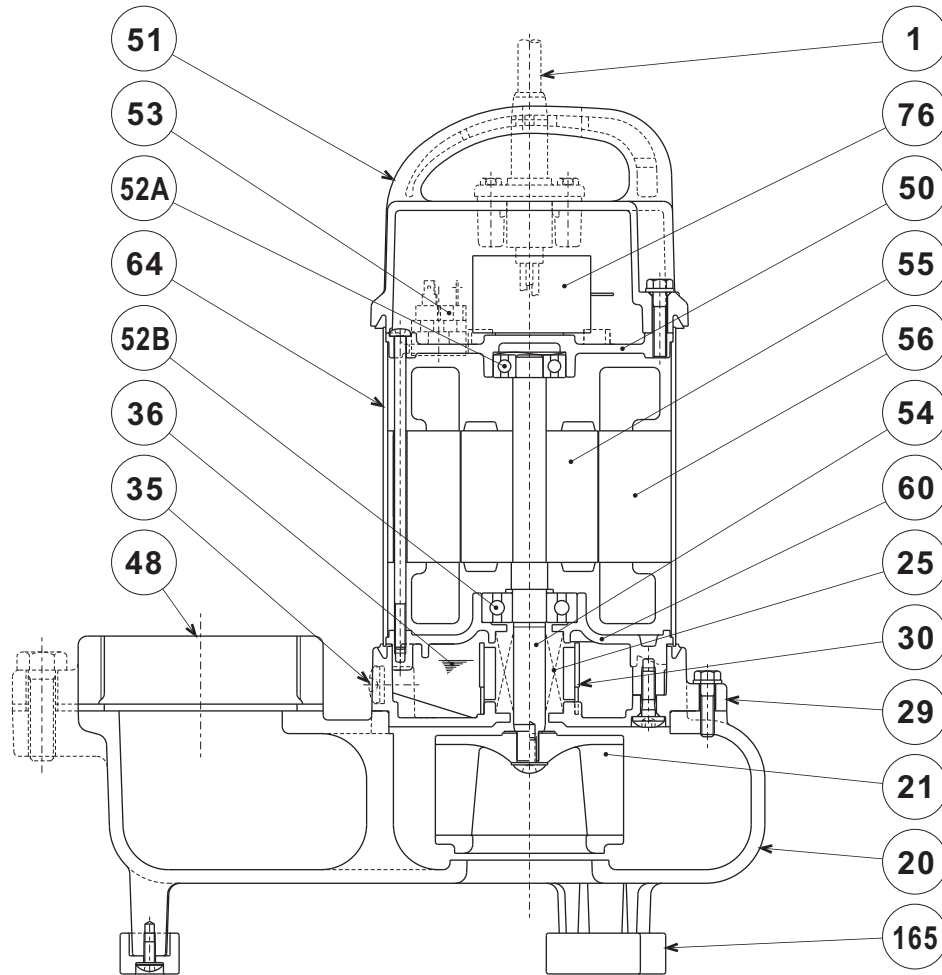

12-PN

| PART# | DESCRIPTION | MAIN MATERIAL / NOTE | RELATED ASTM, AISI CODE | RELATED EN CODE | QTY |
|-------|------------------|----------------------------|-------------------------|------------------|-----|
| 1 | Power Cable | PVC Sheath AWG16/3-20ft | | | 1 |
| 20 | Pump Casing | Cast Iron | A48M Class30B | EN 1561 GJL-200 | 1 |
| 21 | Impeller | PPO Plastic w/GF20 | | | 1 |
| 25 | Mechanical Seal | Silicon Carbide / W-14HL | | | 1 |
| 29 | Oil Casing | PPS Plastic w/GF40 | | | 1 |
| 30 | Oil Lifter | PBT Plastic | | | 1 |
| 35 | Oil Plug | Stainless Steel | S 30400 | 1.4301 | 1 |
| 36 | Lubricant | White Mineral Oil ISO VG32 | | | |
| 48 | Companion Flange | Cast Iron / NPT 3" | A48M Class30B | EN 1561 GJL-200 | 1 |
| 50 | Motor Bracket | Aluminum Alloy Die Casting | B85 383.0 | EN 1706 AC-46100 | 1 |
| 51 | Motor Head Cover | PPS Plastic w/GF40 | | | 1 |
| 52A | Upper Bearing | #6201ZZC3 | | | 1 |
| 52B | Lower Bearing | #6302ZZC3 | | | 1 |
| 53 | Motor Protector | | | | 1 |
| 54 | Shaft | Stainless Steel | S 30400 | 1.4301 | 1 |
| 55 | Rotor | | | | 1 |
| 56 | Stator | | | | 1 |
| 60 | Bearing Housing | Aluminum Alloy Die Casting | B85 383.0 | EN 1706 AC-46100 | 1 |
| 64 | Motor Housing | Stainless Steel | S 30400 | 1.4301 | 1 |
| 76 | Capacitor | | | | 1 |
| 165 | Rubber Cushion | Nitril Butadiene Rubber | | | 3 |